

**ILLUSTRATIONS FOR THE ARTICLE
"FORM IN ARCHITECTURE"**

5) TRADITIONAL AND INNOVATIVE, REGIONAL AND UNIVERSAL IN ARCHITECTURE

5.1 Correlation between these characteristics in different epochs.

"OC" – objective conditions:

1-structures, materials, construction technology, etc. 2-functions in industrial and public buildings; 3-function in dwellings; 4-local conditions (climate, relief, geology, etc).

"CP" – conditions of perception:

PP-psycho-physiological stereotypes; CI – stereotypes of the culture of civilization; CII – stereotypes of the culture epoch; CIII – stereotypes of the culture of social groups.

Forms: I-universal; II-regional; III-innovative; IV-traditional.

A. Historical epochs.

Predominance of regional and traditional as a result of the stability of objective conditions and weakness of connections between regions. On that basis, various Regional Architectures were formed in historical epochs.

B. The present.

Predominance of the universal and innovative as a result of high mobility of objective conditions and development of connections between regions. On that basis, universal cosmopolitan Architecture with a very scanty collection of Forms, was formed.

C. Expedient ways for change of the present situation.

Revival of the Forms traditional for the given regions, first of all – in the sphere of habitation, realized by re-creation of a part of traditional methods of taking local conditions into account, as well as stereotype Forms- Symbols, which are deeply implanted in their culture.

A

B

C

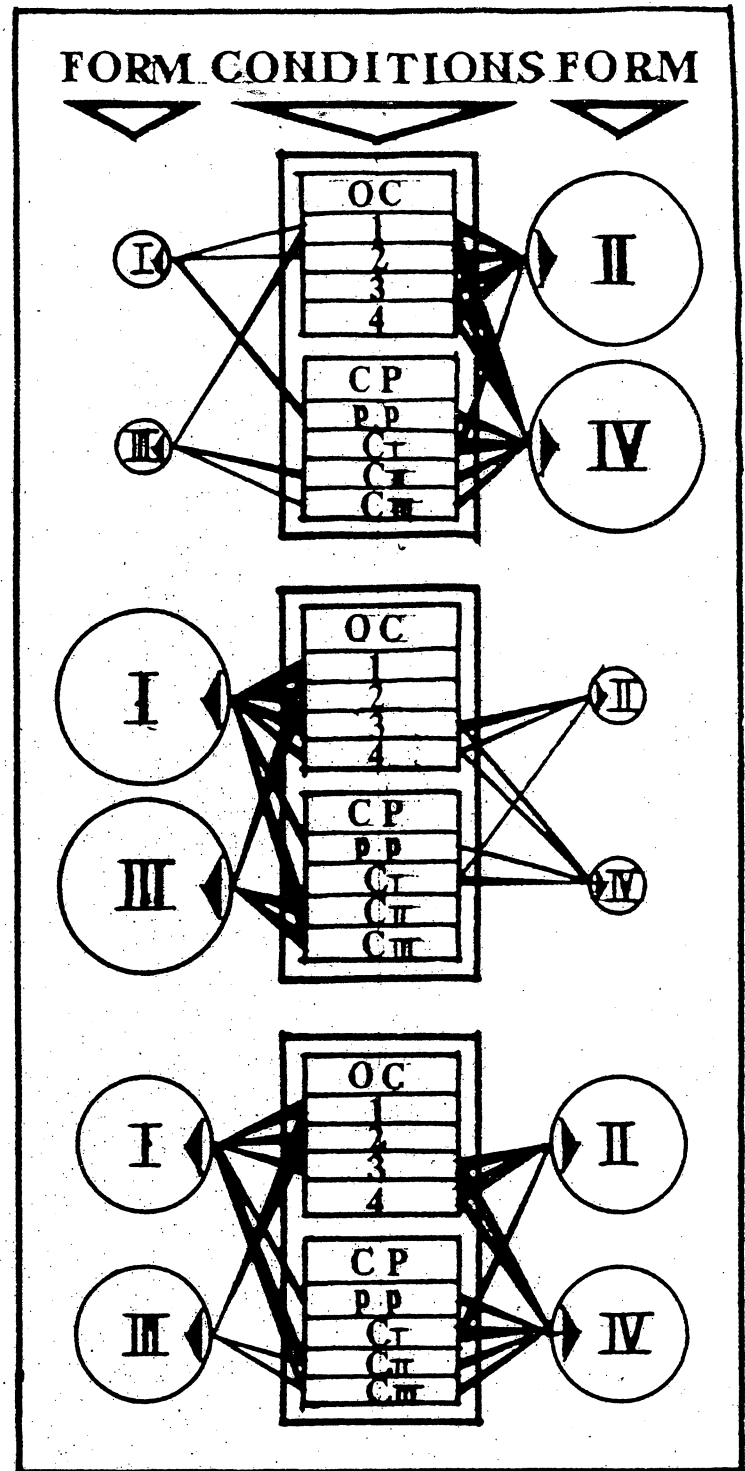

5.1.

5.2 Examples of traditional stereotype Forms – Symbols of different civilizations.

Casing-a constructively necessary element of Russian folk wooden dwellings and its representation as a stereotype Form – symbol in edifices of the Russian classicism of the XVIII-XIX centuries, which became an element of Regional Architecture.

Capitals-tribal totems in the Caucasus civilization.

Rosette-symbol of the sun, wheel, motion of life, and life itself in different civilizations.

Bay in the wall of temples or dwellings – an important stereotype Form in Asian civilization.

Cupola-symbol of the sky and peace in the European and Asian civilizations, passed to the most important public edifices.

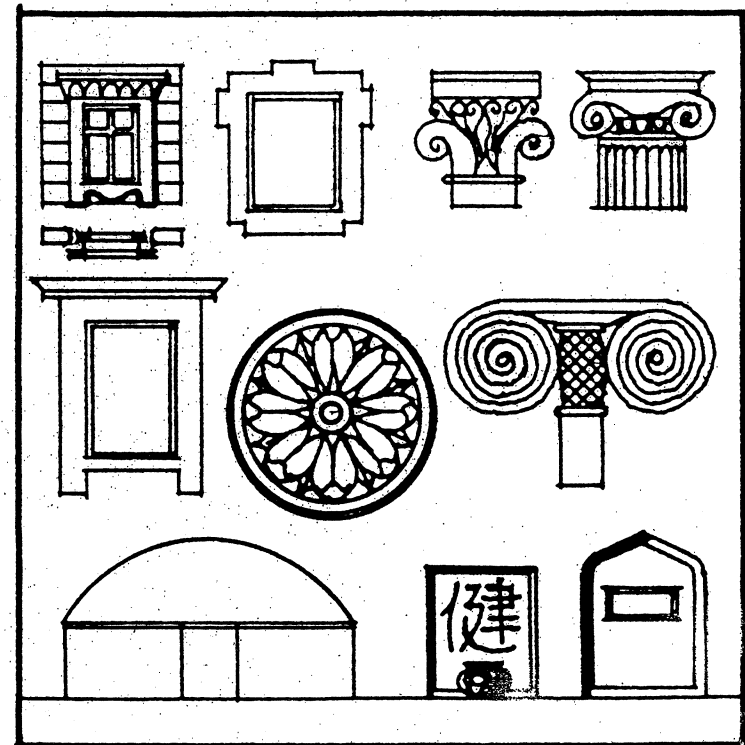

5.

5.2.

Victor Machinsky